

ADVANCED Line Comfort 2 TW

Schneider
my ultimate mirror experience

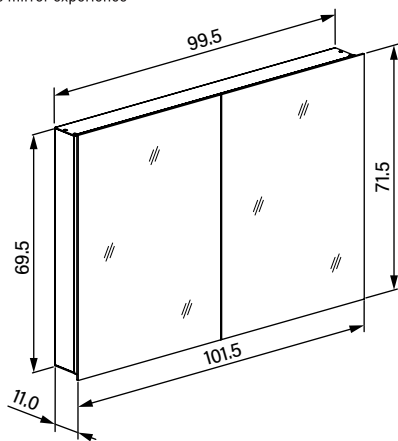

LED
2000 -
6500 K



Artikel 1. Ausgabe
Article **622 035** 1. Edition **04-2021**
Articolo 1. Edizione

Art. No. **194.100** Mut.

Spiegelschrank ALC2 100/2/TW
Armoire-miroir ALC2 100/2/TW
Armadio specchio ALC2 100/2/TW

W. Schneider+Co AG, CH-8135 Langnau a.A.
www.wschneider.com © 2021

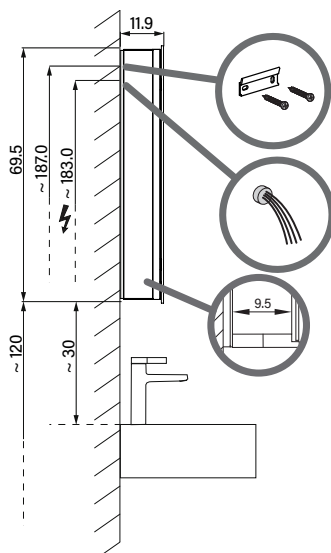

Aufputz-Montage **AP**
Pose en applique
Surface mounting

| ALC2/TW/AP | A |
|------------|-----|
| 50.. | 19 |
| 60.. | 29 |
| 70.. | 39 |
| 80.. | 49 |
| 90.. | 59 |
| 100.. | 69 |
| 120.. | 89 |
| 130.. | 99 |
| 140.. | 109 |
| 150.. | 119 |

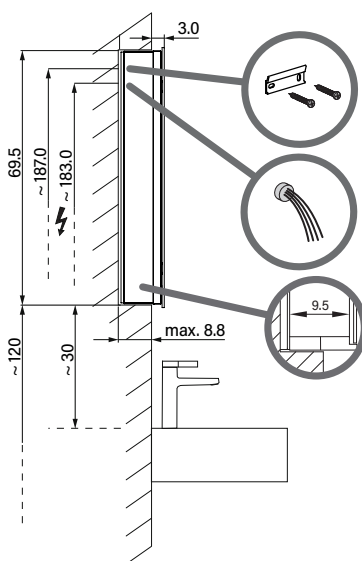
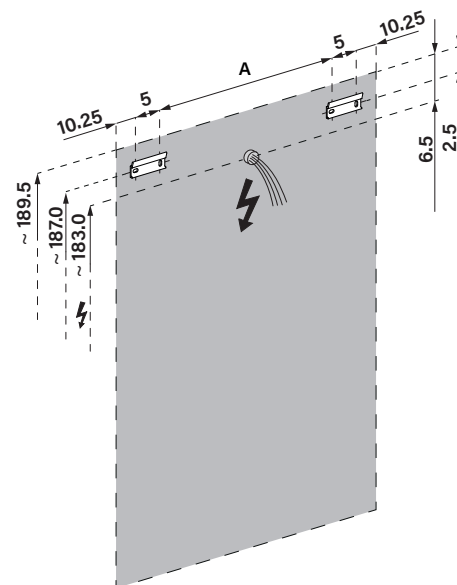

Unterputz-Montage **UP**
Pose en encastrement
Recessed mounting

| ALC2/UP | B |
|---------|-------|
| 50.. | 49.5 |
| 60.. | 59.5 |
| 70.. | 69.5 |
| 80.. | 79.5 |
| 90.. | 89.5 |
| 100.. | 99.5 |
| 120.. | 119.5 |
| 130.. | 129.5 |
| 140.. | 139.5 |
| 150.. | 149.5 |

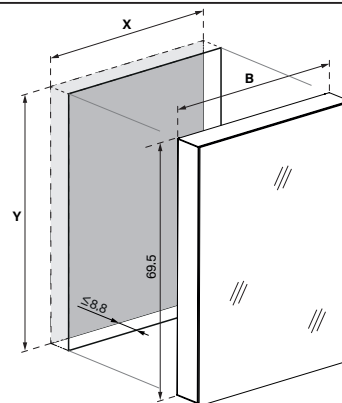

UP-Montage: Nischengröße X x Y und Befestigung Spiegelschrank sind baueits zu bestimmen.

Montage encastré: la taille de la niche X x Y et la fixation de l'armoire-miroir doivent être déterminées par le client.

Flush mounting: the recess dimensions X by Y and the fixing system for the mirrored cabinet will need to be determined on site.

Die Massangaben in cm verstehen sich unter dem Vorbehalt der Werkstoleranzen, eventuell späterer Änderungen sowie weiterer Montagemöglichkeiten. Die Haftung für Folgen fehlerhafter oder unvollständiger Massangaben ist ausgeschlossen. (Art. 100 OR).

Les dimensions en cm s'entendent sous réserve des tolérances d'usine, d'éventuelles modifications ultérieures, de même que de nouvelles possibilités de montage. La responsabilité ne peut être engagée en cas de cotes manquantes ou erronées (CD art. 100).

Le dimensioni in cm s'intendono fatte salve le tolleranze di fabbricazione, le eventuali modifiche successive e le ulteriori alternative di montaggio. Si declina qualsiasi responsabilità per le conseguenze legate a dimensioni errate o incomplete (art. 100 CO).